

E72	E72: Drying NTC sensor on condenser faulty	E72
Ohm value of the NTC out of limits		

Checks to perform: *Check that all the connectors are inserted correctly*

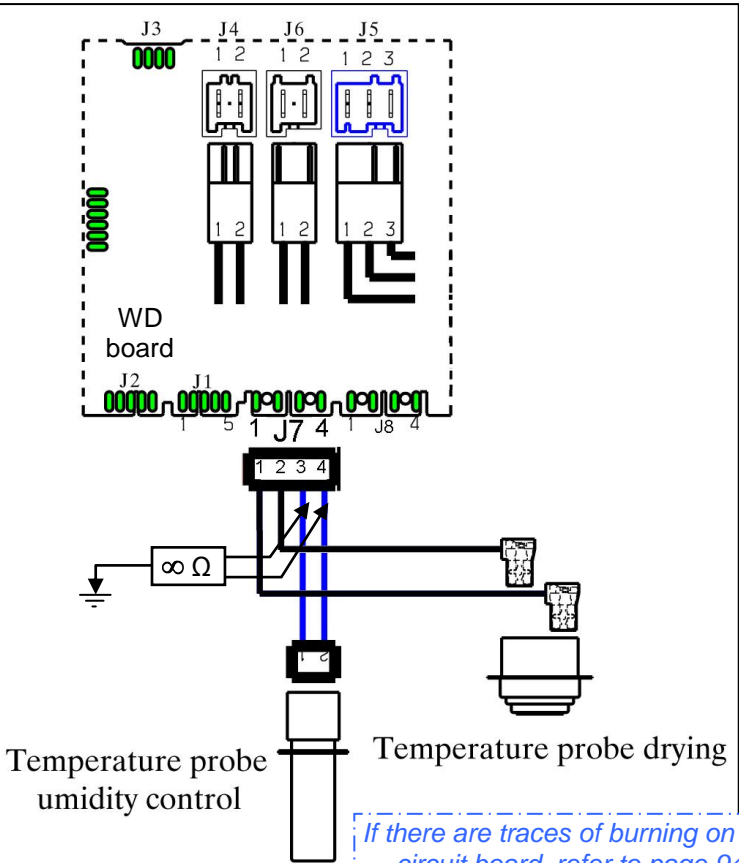
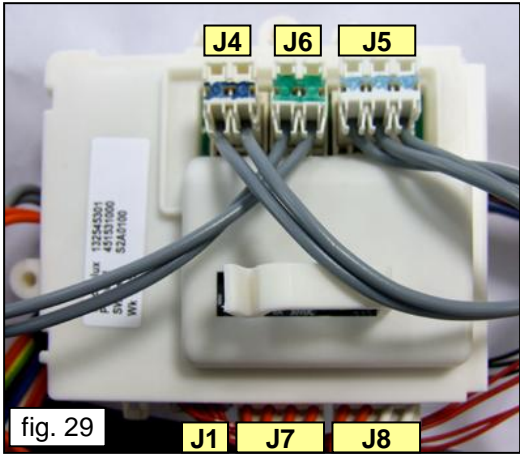
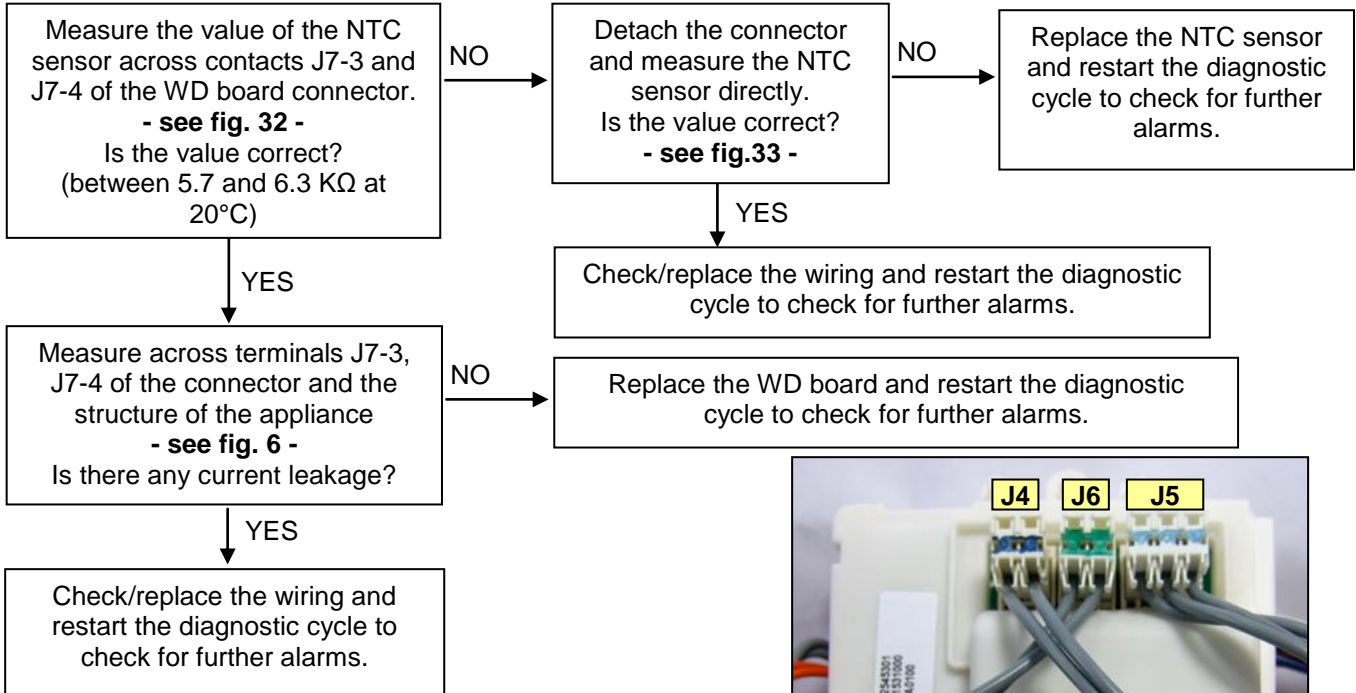

E73	E73: NTC sensor on drying duct faulty	E73
Ohm value of the NTC out of limits		

Checks to perform: Check that all the connectors are inserted correctly

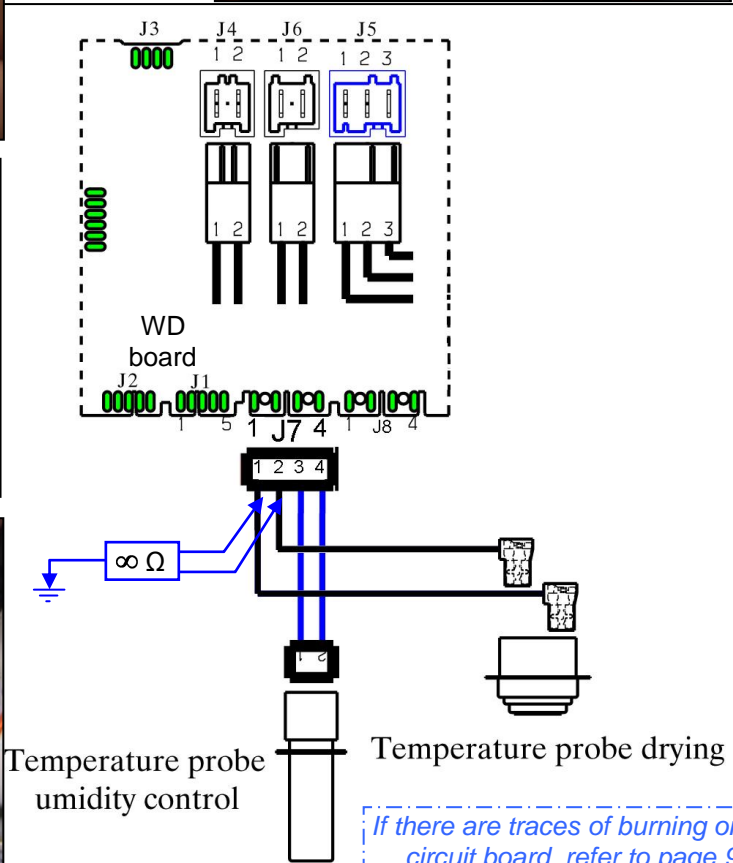
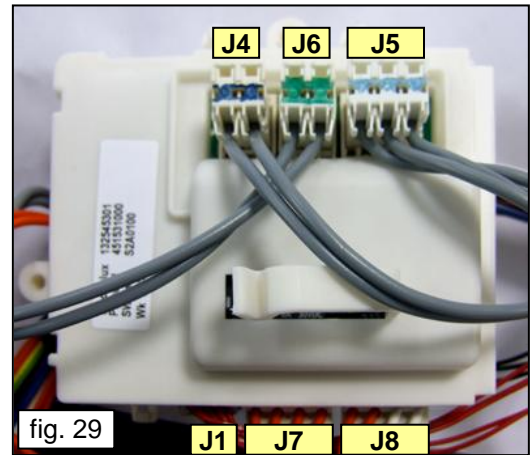
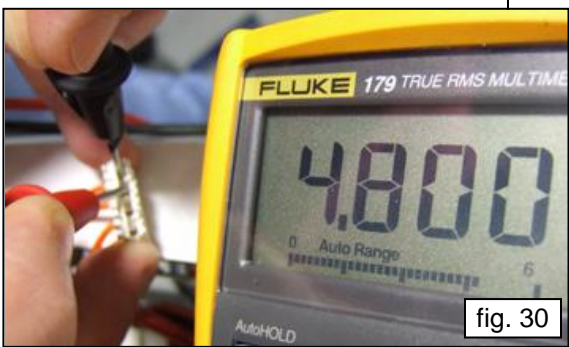
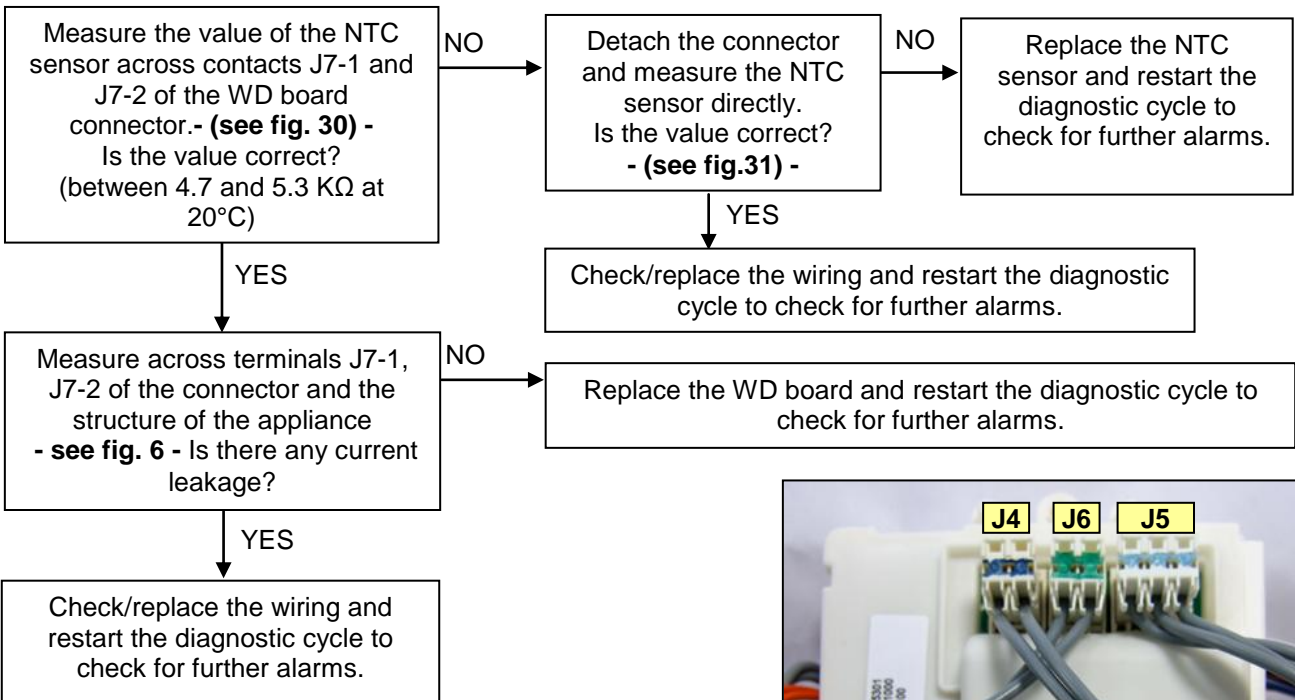

Checks to perform: Check that all the connectors are inserted correctly

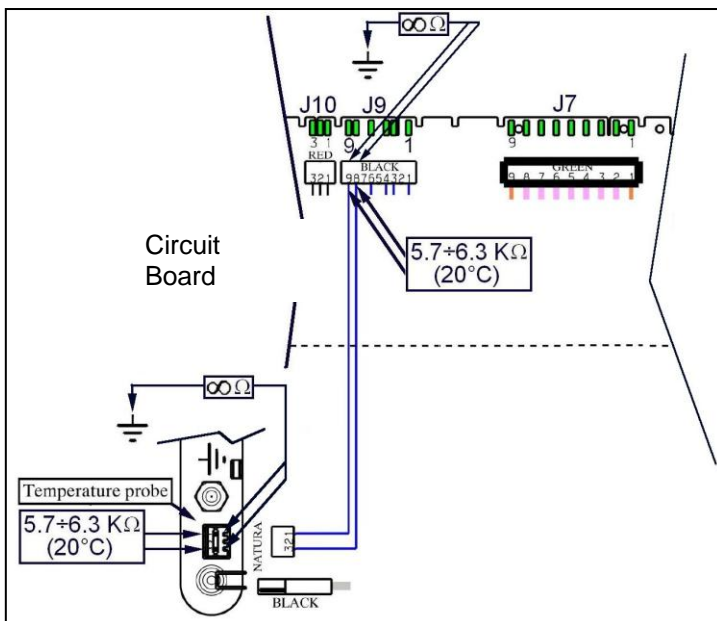
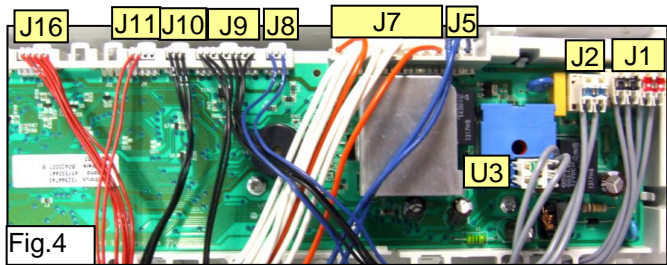
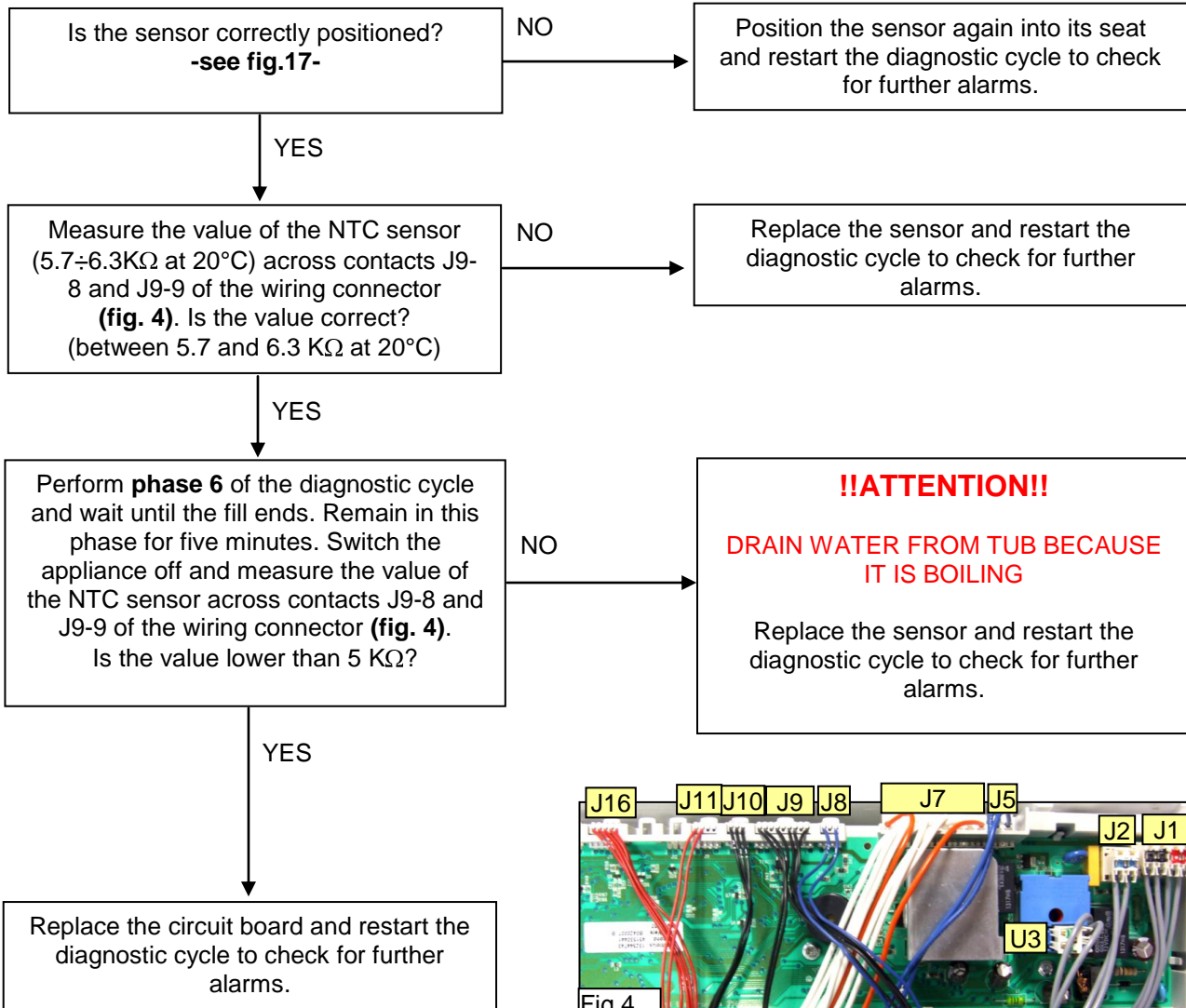

If there are traces of burning on the circuit board, refer to page 94

