

RESİM ÜZERİNDEKİ ÖLÇÜ ALINMAYIZ / DO NOT SCALE

■ Tam bandajlama (Full bandage)
 ▨ 5-6 mm aralıklı bandajlama (5-6mm intermittent bandage)

GAD KONTROL

GAD İLE ÇİZİMLİ ŞİŞİR ELDE DEĞİŞİTİRİLMİYİZ / CAD OUTPUT IS NOT HANDWRK

TİP/FOR TYPE07-09-13-21-27-29-37-39

41-43-45-51-57-63-69-83-85 DR

TİP/FOR TYPE41-43-45-85

1730±10

TİP/FOR TYPE07-08-09-10-13-14-21-22-23-24-25-26-27-28-29-30-35-36-37-38-39-40-41-42-43-44-45-46-51-52-53-54-55-56-57-58-59-60-61-62-63-64-65-66-67-68-69-70-71-72-73-74-75-76-77-78-79-80-81-82-83-84-85-86 DR

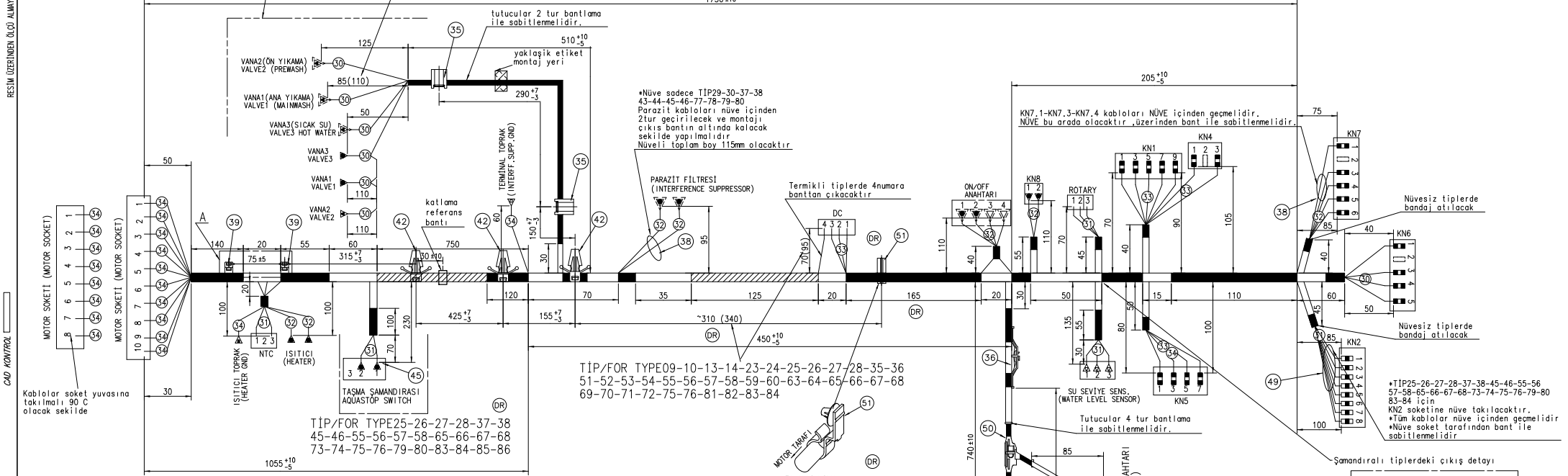

Kablolar soket yuvasına takılmalı, 90 C olacak şekilde

GAD KONTROL

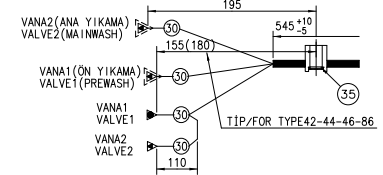
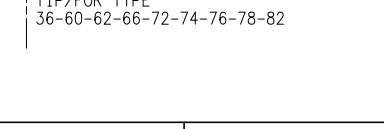
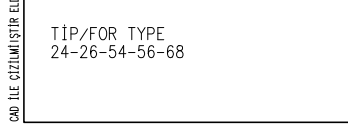
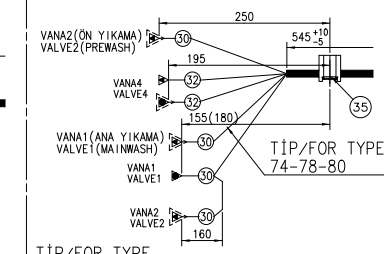
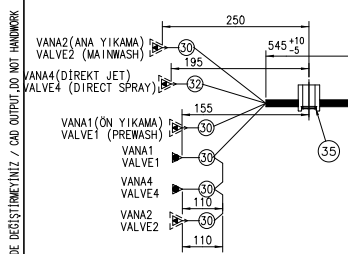
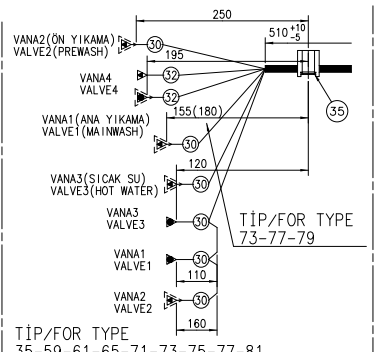
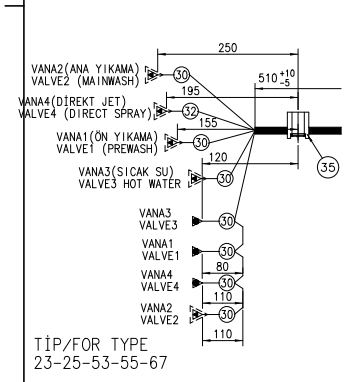

TİP/FOR TYPE08-10-14-22-28-30-38-40-42-44-46-52-58-64-70-84-86 DR

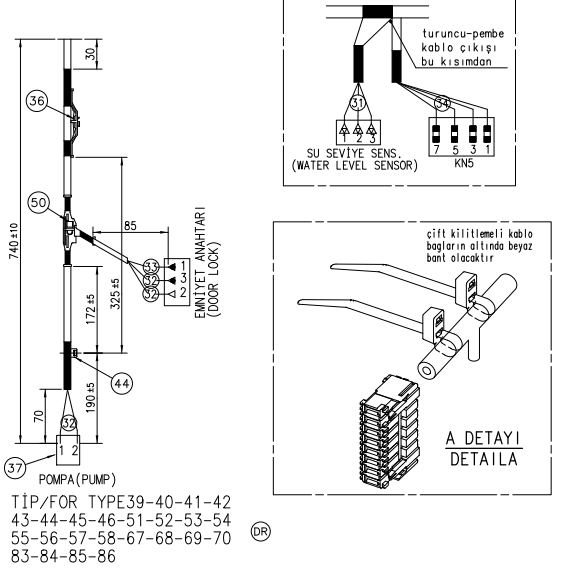
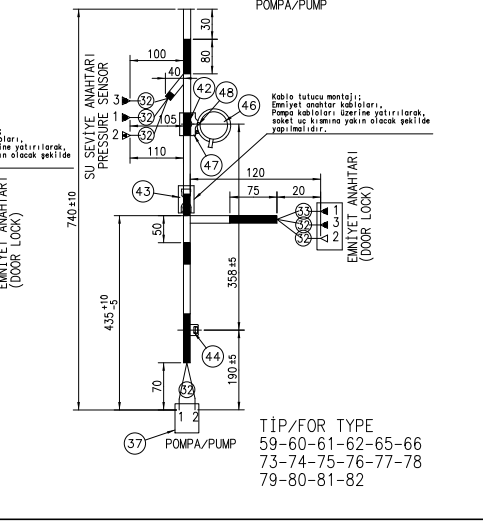
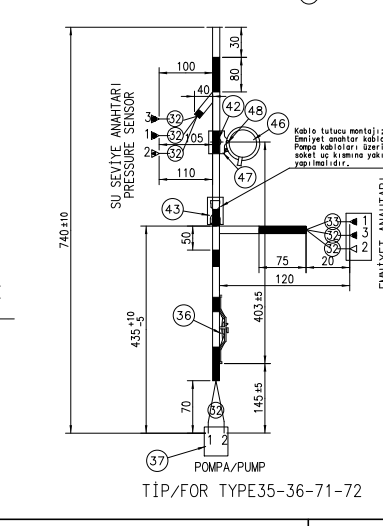

02/01 Tip Malzeme Renk Standart Ölçü		arçelik		MALZEME/MATERIAL	
TARİH	İSİM	ANA KABLO GR			
13.01.2009	ÖZLEM	MAIN CABLE HARNESS			
13.01.2009	FARUK	TRVO/1/2/MED/UN-JUN/NCR-COMP.			
13.01.2009	PARMAKSIZ	DIFFUSION/FUSION MINI LCD			
TOLERANS		KONTROL		RESİM NO.	
Verilmeyen Ölçü (DIN)		No.Sınıflı Komp. Sıra No		Tip İst. Değ.	
+10 / -5		287580/XX/00		Sayı No.	
		YERİNE GEÇTİ		Tarih	

RESİM KONTROL

